

### GENERAL DESCRIPTION

The HI-8425 is a combined 8-channel discrete-to-digital sensor and quad low side driver fabricated with Silicon-on-Insulator (SOI) technology for robust latch-up free operation. Sense detection can either be GND/Open or Supply/Open as configured by the SNSE\_SEL pin. Supply/Open sensing is also referred to as 28V/Open sensing. The sensing circuit window comparator thresholds can be fixed at the internal programmed values or can be set externally at the HI\_SET and LO\_SET pins, as selected by the THS\_SEL pin. The digital SENSE outputs can be tri-stated by taking the OE pin high.

All sense inputs are internally lightning protected to DO160G, Section 22, Cat AZ, BZ and ZZ without external components.

The HI-8425 also offers four low side switches each capable of sinking 200 mA of current. Each switch transistor is controlled by its own digital input pin and is fully fault protected. Over-current conditions, such as a short circuit, are detected and inhibited while signaling the fault condition at the corresponding logic output. These four FAULT outputs are also available in a combined OR output. The outputs are fully protected from transients when driving relays.

The HI-8426 puts all of the features of the HI-8425 except the individual Fault Detection Outputs, Tri-state pin selection and fixed internal thresholds into a 32-pin Chip Scale Package (QFN) which measures only 5mm x 5mm.

Interface to the digital subsystem is simple CMOS logic inputs and outputs. The logic pins are compatible with 5V or 3.3V logic allowing direct connection to a wide range of microcontrollers or FPGAs.

### FEATURES

- Robust CMOS Silicon-on-Insulator (SOI) technology
- 8-channel Selectable Sense Operation, GND/Open or Supply/Open
- Selectable Thresholds and Hysteresis
- Sense Detection Range 3V to 22V
- Logic Operation from 3.0V to 5.5V
- Lightning Protected Sense Inputs
- Sense Inputs compliant to MIL-STD-704

- Airbus ABD0100H compliant sense inputs
- 4 Low-Side 200 mA drivers
- 4.5 Ohm On Resistance
- Over-Current Fault Detection Signaled by Logic Output
- Max Power Dissipation Automatically Limited by Fault Protection
- Diode Clamps for Discharging Inductive Loads

### APPLICATIONS

- Avionics Discrete to Digital Sensing
- Relay Driver
- Lamp driver
- Discrete Signaling

### PIN CONFIGURATIONS

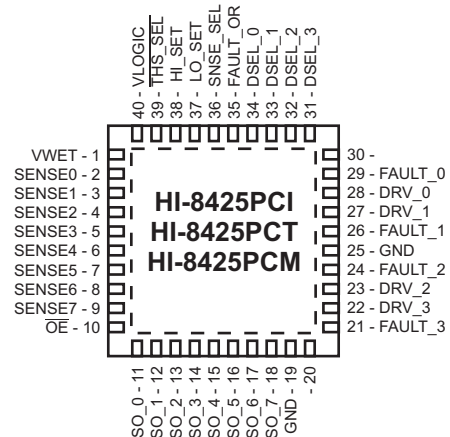

**40 Pin Plastic 6mm x 6mm  
Chip-scale package (QFN)**

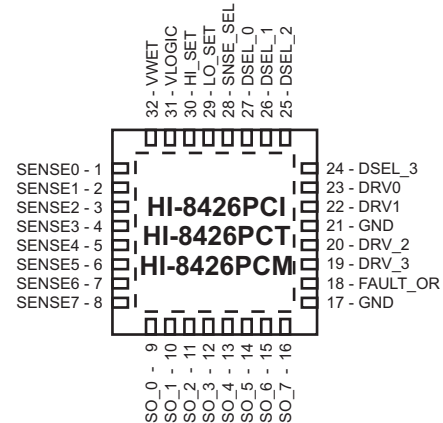

**32 Pin Plastic 5mm x 5mm  
Chip-scale package (QFN)**

(See page 16 for leaded QFP package options)

**BLOCK DIAGRAM**

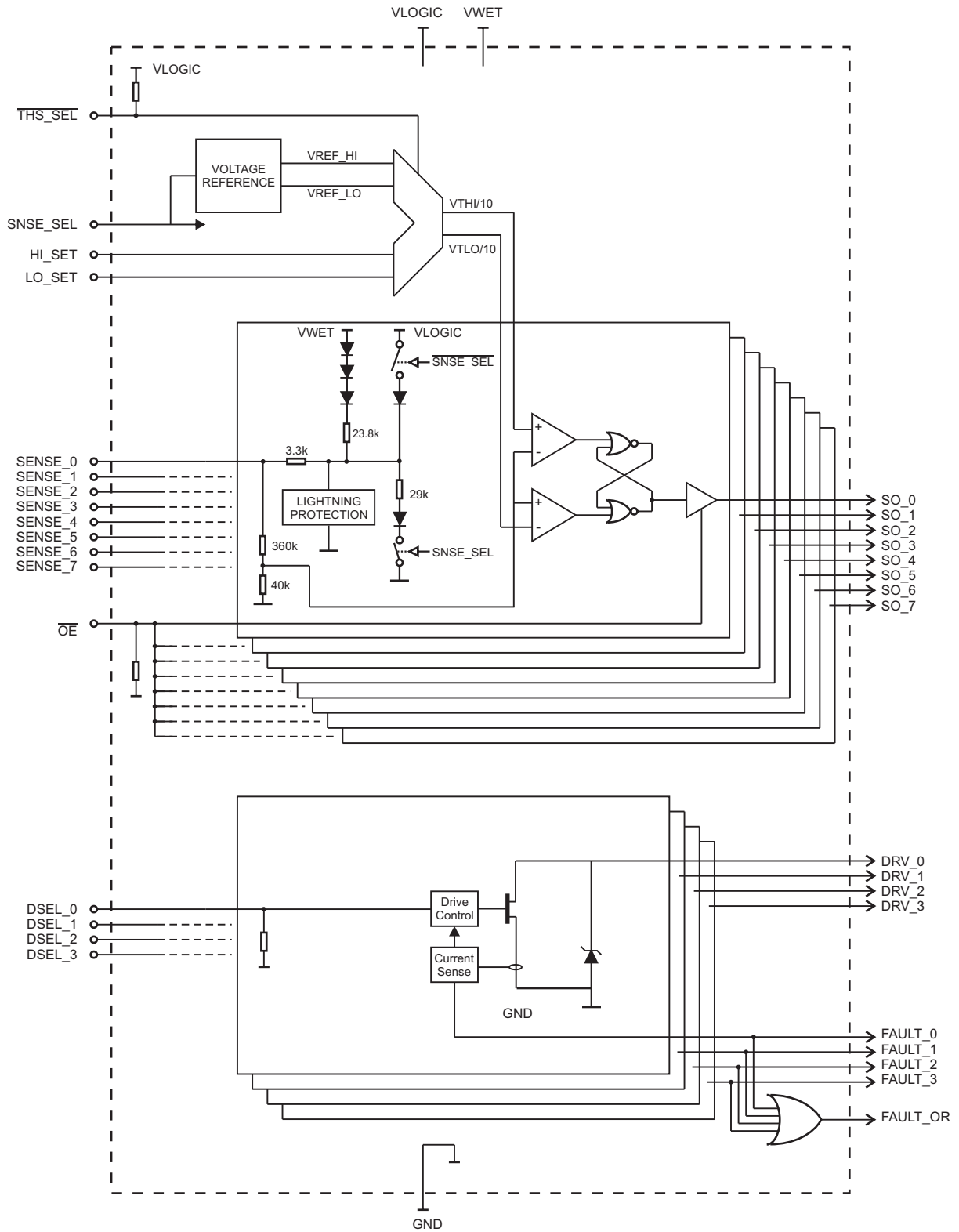

**Figure 2**

## PIN DESCRIPTIONS

SYMBOL	FUNCTION	DESCRIPTION
VWET	Supply	Optional input to supply relay wetting current to sense lines in GND/Open operation 50kΩ to GND
SENSE0	Discrete Input	Discrete input 0. If SNSE_SEL = 0 pin senses GND/Open. If SNSE_SEL = 1, senses SUPPLY/Open
SENSE1	Discrete Input	Discrete input 1. If SNSE_SEL = 0 pin senses GND/Open. If SNSE_SEL = 1, senses SUPPLY/Open
SENSE2	Discrete Input	Discrete input 2. If SNSE_SEL = 0 pin senses GND/Open. If SNSE_SEL = 1, senses SUPPLY/Open
SENSE3	Discrete Input	Discrete input 3. If SNSE_SEL = 0 pin senses GND/Open. If SNSE_SEL = 1, senses SUPPLY/Open
SENSE4	Discrete Input	Discrete input 4. If SNSE_SEL = 0 pin senses GND/Open. If SNSE_SEL = 1, senses SUPPLY/Open
SENSE5	Discrete Input	Discrete input 5. If SNSE_SEL = 0 pin senses GND/Open. If SNSE_SEL = 1, senses SUPPLY/Open
SENSE6	Discrete Input	Discrete input 6. If SNSE_SEL = 0 pin senses GND/Open. If SNSE_SEL = 1, senses SUPPLY/Open
SENSE7	Discrete Input	Discrete input 7. If SNSE_SEL = 0 pin senses GND/Open. If SNSE_SEL = 1, senses SUPPLY/Open
$\overline{OE}$	Digital Input	If High, SO_n and fault outputs are high-impedance. $\overline{OE}$ has internal 30kΩ pull-down resistor
SO_0	Digital output	High if SNSE_SEL=0 and SENSE0 < V <sub>LO</sub> , or Low if SNSE_SEL=1 and SENSE0 > V <sub>HI</sub>
SO_1	Digital output	High if SNSE_SEL=0 and SENSE1 < V <sub>LO</sub> , or Low if SNSE_SEL=1 and SENSE1 > V <sub>HI</sub>
SO_2	Digital output	High if SNSE_SEL=0 and SENSE2 < V <sub>LO</sub> , or Low if SNSE_SEL=1 and SENSE2 > V <sub>HI</sub>
SO_3	Digital output	High if SNSE_SEL=0 and SENSE3 < V <sub>LO</sub> , or Low if SNSE_SEL=1 and SENSE3 > V <sub>HI</sub>
SO_4	Digital output	High if SNSE_SEL=0 and SENSE4 < V <sub>LO</sub> , or Low if SNSE_SEL=1 and SENSE4 > V <sub>HI</sub>
SO_5	Digital output	High if SNSE_SEL=0 and SENSE5 < V <sub>LO</sub> , or Low if SNSE_SEL=1 and SENSE5 > V <sub>HI</sub>
SO_6	Digital output	High if SNSE_SEL=0 and SENSE6 < V <sub>LO</sub> , or Low if SNSE_SEL=1 and SENSE6 > V <sub>HI</sub>
SO_7	Digital output	High if SNSE_SEL=0 and SENSE7 < V <sub>LO</sub> , or Low if SNSE_SEL=1 and SENSE7 > V <sub>HI</sub>
FAULT_3	Digital output	High if Driver 3 is attempting to sink excess current
DRV_3	Switch Output	Drain node of Ground switch driver 3
GND	Supply	Ground for logic and Analog Ground return for DRV0-3. GND pin and the isolated backside pad should be grounded for optimum performance and power dissipation.
DRV_2	Switch Output	Drain node of Ground switch driver 2
FAULT_2	Digital output	High if Driver 2 is attempting to sink excess current
FAULT_1	Digital output	High if Driver 1 is attempting to sink excess current
DRV_1	Switch Output	Drain node of Ground switch driver 1
DRV_0	Switch Output	Drain node of Ground switch driver 0
FAULT_0	Digital output	High if Driver 0 is attempting to sink excess current
DSEL_3	Digital Input	When high, turns on Driver 3. DSEL_3 has an internal 30kΩ pull-down resistor
DSEL_2	Digital Input	When high, turns on Driver 2. DSEL_2 has an internal 30kΩ pull-down resistor
DSEL_1	Digital Input	When high, turns on Driver 1. DSEL_1 has an internal 30kΩ pull-down resistor
DSEL_0	Digital Input	When high, turns on Driver 0. DSEL_0 has an internal 30kΩ pull-down resistor
FAULT_OR	Digital Output	High if any Driver is attempting to sink excess current
SNSE_SEL	Digital Input	If Low, SENSE pins are sensing Open/Gnd. If High, SENSE pins sense SUPPLY/Open
LO_SET	Analog input	If $\overline{THS\_SEL}$ is High, this pin sets the lower window comparator threshold
HI_SET	Analog input	If $\overline{THS\_SEL}$ is High, this pin sets the upper window comparator threshold
$\overline{THS\_SEL}$	Digital Input	If $\overline{THS\_SEL}$ is Low, comparator thresholds are set internally. $\overline{THS\_SEL}$ has an internal 30kΩ pull-up
VLOGIC	Supply	Logic supply. (3.0V - 5.5V)

## FUNCTIONAL DESCRIPTION

### SENSING

The 8 Sense Channels can be configured to meet the requirements of a variety of conditions and applications. Table 1 summarizes basic function selection and Table 2 gives more details on possible threshold values.

### GND/OPEN SENSING

For GND/Open sensing, the SNS\_SEL pin is connected to GND. Referring to the Block Diagram, Figure 2, this selection will connect a 3.3kΩ pull-up resistor through a diode to VLOGIC and a 23.8kΩ resistor through 3 diodes to VWET. These resistors give extra noise immunity for detecting the open state while providing relay wetting current. Configuring THS\_SEL, HI\_SET/LO\_SEL and VWET as described below sets the window comparator thresholds, VTHI and VTLO, the open input voltage when open, and the input current.

#### HI-8425 (40 pin version) - THRESHOLD SELECT

The HI-8425 offers a choice between internally fixed thresholds or external thresholds provided by the user. With THS\_SEL set to GND, the window comparator thresholds are fixed based on an internal reference. The high threshold, VTHI, and the low threshold, VTLO levels may be found in Table 2. When the internal references are used the HI\_SET and LO\_SET pins should be connected to GND. For applications with either large GND offsets or thresholds higher than VLOGIC - 0.75V, THS\_SEL is set high and the thresholds are set externally, for example by a simple resistor divider off the VLOGIC supply. In this case VTHI is equal to 10X the voltage on the HI\_SET pin. VTLO is equal to 10X the voltage on the LO\_SET pin. This mode allows the user complete flexibility to define the thresholds and hysteresis levels.

#### HI-8426 (32 pin version) THRESHOLD SELECT

For applications that can take advantage of the very small 32 pin chip scale package of the HI-8426, THS\_SEL is not available and an internal pull-up makes it mandatory to supply HI\_SET and LO\_SET externally.

### OPEN INPUT VOLTAGE

For correct operation, the VSENSE\_n when open, must be higher than VTHI so SO\_n will be low. This condition requires VWET to be set greater than (VTHI/0.9 + 2.25V). Various ARINC standards such as ARINC 763 define the standard “Open” signal as characterized by a resistance of 100kΩ or more with respect to signal common. The user should consider this 100kΩ to ground case when setting the thresholds.

### WETTING CURRENT

For GND/Open applications with VWET open, the wetting current with the input voltage at GND is simply (VLOGIC - 0.75)/3.3k. When applying a higher voltage at the VWET pin the wetting current is (VLOGIC - 0.75)/3.3k + (VWET - 4.2)/127k. Additional wetting current can be achieved by placing an external resistor and a diode between VWET and the individual sense inputs.

### SUPPLY/OPEN SENSING

The 8 Sense Channels can be configured to sense Supply/Open by connecting the SNSE\_SEL pin to VLOGIC. Referring to Figure 2, a 32kΩ resistor is switched in series to provide a pull down in addition to the 400kΩ of the comparator input divider to GND. Similar to the GND/Open case configuring THS\_SEL, HI\_SET/LO\_SEL and VWET as described below sets the window comparator thresholds, the open input voltage when open and the wetting current.

### THRESHOLD SELECT

The threshold selections are handled in the same way as stated above for the GND/OPEN case. For THS\_SEL set low, the internal reference nominally sets the window comparator. See table 2 for the VTHI and VTLO threshold levels. For THS\_SEL set high, the final thresholds are 10X the voltage set on the HI\_SET and LO\_SET pins. The VWET pin must be left open in the Supply/Open sensing case.

### WETTING CURRENT

For the Supply/Open case the wetting current into the sense input is the current sunk by the effective 28kΩ to GND. For VSENSE\_n = 28V, IWET is 1ma. See Figure 12.

Table 1. Function Table

SENSE_n	SNSE_SEL	$\overline{OE}$	SO_n
Open or > VTHI	L (GND/OPEN)	L	L
< VTLO	L (GND/OPEN)	L	H
X	L (GND/OPEN)	H	Z
Open or < VTLO	H (V+/OPEN)	L	H
> VTHI	H (V+/OPEN)	L	L
X	H (V+/OPEN)	H	Z

H = VLOGIC, L = GND, Z = Hi-Z, X = Don't Care, V+ = VSUPPLY  
See Table 2 for values of VTHI/VTLO

## FUNCTIONAL DESCRIPTION

Table 2. Configuration options and allowed threshold values -55C to 125C.

VLOGIC	VWET Pin	SNSE_SEL	$\overline{\text{THS\_SEL}}$	Operation	Threshold Selected	Maximum HI_SET (VTHI = HI_SETx10)	Minimum LO_SET (VTLO = LO_SETx10)	Guaranteed High Threshold	Guaranteed Low Threshold
3.15V	OPEN	L	L	GND/OPEN	Internal	-	-	2.5V	1.0V
3.6V	OPEN	L	L	GND/OPEN	Internal	-	-	2.7V	1.0V
3.3V	28V	L	L	GND/OPEN	Internal	-	-	2.55V	1.0V
3.0V	7V	L	H	GND/OPEN	External	0.4V (4.0V)	0.3V (3.0V)	VTHI + 0.5V	VTLO - 0.5V
3.6V	7V	L	H	GND/OPEN	External	0.4V (4.0V)	0.3V (3.0V)	VTHI + 0.5V	VTLO - 0.5V
3.0V to 3.6V	28V	L	H	GND/OPEN	External	2.2V (22V)	0.3V (3.0V)	VTHI + 0.5V	VTLO - 0.5V
3.0V to 3.6V	OPEN	H	L	V+/OPEN	Internal	-	-	15.5V	11.0V
3.0V to 3.6V	OPEN	H	H	V+/OPEN	External	2.2V (22V)	0.3V (3.0V)	VTHI + 0.5V	VTLO - 0.5V
4.5V	OPEN	L	L	GND/OPEN	Internal	-	-	3.25V	1.0V
5.5V	OPEN	L	L	GND/OPEN	Internal	-	-	3.75V	1.0V
5.0V	28V	L	L	GND/OPEN	Internal	-	-	3.5V	1.0V
4.5V	7V	L	H	GND/OPEN	External	0.4V (4.0V)	0.3V (3.0V)	VTHI + 0.5V	VTLO - 0.5V
5.5V	7V	L	H	GND/OPEN	External	0.4V (4.0V)	0.3V (3.0V)	VTHI + 0.5V	VTLO - 0.5V
4.5V to 5.5V	28V	L	H	GND/OPEN	External	2.2V (22V)	0.3V (3.0V)	VTHI + 0.5V	VTLO - 0.5V
4.5V to 5.5V	OPEN	H	L	V+/OPEN	Internal	-	-	15.5V	11.0V
4.5V to 5.5V	OPEN	H	H	V+/OPEN	External	2.2V (22V)	0.3V (3.0V)	VTHI + 0.5V	VTLO - 0.5V

NOTE: VTHI = Sense pin high threshold (HI\_SET x 10), VTLO = Sense pin low threshold (LO\_SET x 10)

## OUTPUT ENABLE

The output enable pin,  $\overline{\text{OE}}$ , available on the HI-8425, tri-states all Sense Outputs and Low Side Driver Fault Outputs to allow connecting the tri-state outputs in parallel with other tri-stated chips. The  $\overline{\text{OE}}$  pin has a pull-down and when left open will cause these digital outputs to be driven to their logic levels. If the  $\overline{\text{OE}}$  pin is High, these digital outputs are high impedance.

## OUTPUT DRIVERS

### LOW SIDE DRIVERS

Both product versions offer four Low Side Drivers. Each driver (NMOS switch) is capable of sinking a minimum of 200mA while exhibiting a  $R_{on}$  of 4.5 $\Omega$  typical. Each output has diode clamps for protection during inductive kick-back for relay applications. Off-state leakage is typically less than 10nA at room temperature. The inputs, DSEL0 through DSEL3, have internal pull-downs which hold off the drivers until logic highs are presented.

## OVER-CURRENT SHUTDOWN

Maximum DC power dissipation per driver is approximately 0.5W at room temperature. Conditions that would cause the power to exceed this amount will result in a shut down of the driver. Over-current shutdown is initiated when the driver pin voltage is more than approximately 1.5V from GND. However there is a delay of approximately 11 $\mu$ sec before the shutdown actually occurs giving the driver an opportunity to charge capacitive loads and thereby avoid shutdown. Similarly, if the driver is on and a high load is suddenly switched on, the over-current shutdown will be delayed in activation. Note that even when the over-current fault condition is present, the driver pin is still sinking a few milliamps. This low current condition continues until the input is taken low or the load is removed.

## FAULT CONDITIONS

Each driver has a converter that translates an over-current detection into a logic high output at its FAULT output. The FAULT\_OR output goes high if one or more FAULT outputs are high. These outputs can be tri-stated by setting  $\overline{\text{OE}}$  high.

## FUNCTIONAL DESCRIPTION

### LIGHTNING PROTECTION

All SENSE\_n inputs are protected to RTCA/DO-160G, Section 22, Categories AZ and BZ, Waveforms 3, 4, 5A. In addition, all inputs are also protected to ZZ, Waveforms 3 and 5B, to provide more robustness in composite airframe applications. Table 3 and Figure 3 give values and waveforms. See Application Note AN-305 for recommendations on lightning protection of Holt's family of Discrete-to-Digital devices.

Level	Waveforms			
	3/3	4/1	5A/5A	5B/5B
	Voc (V) / Isc (A)	Voc (V) / Isc (A)	Voc (V) / Isc (A)	Voc (V) / Isc (A)
2	250/10	125/25	125/125	125/125
Z	500/20	300/60	300/300	300/300
3	600/24	300/60	300/300	300/300

Table 3. Waveform Peak Amplitudes

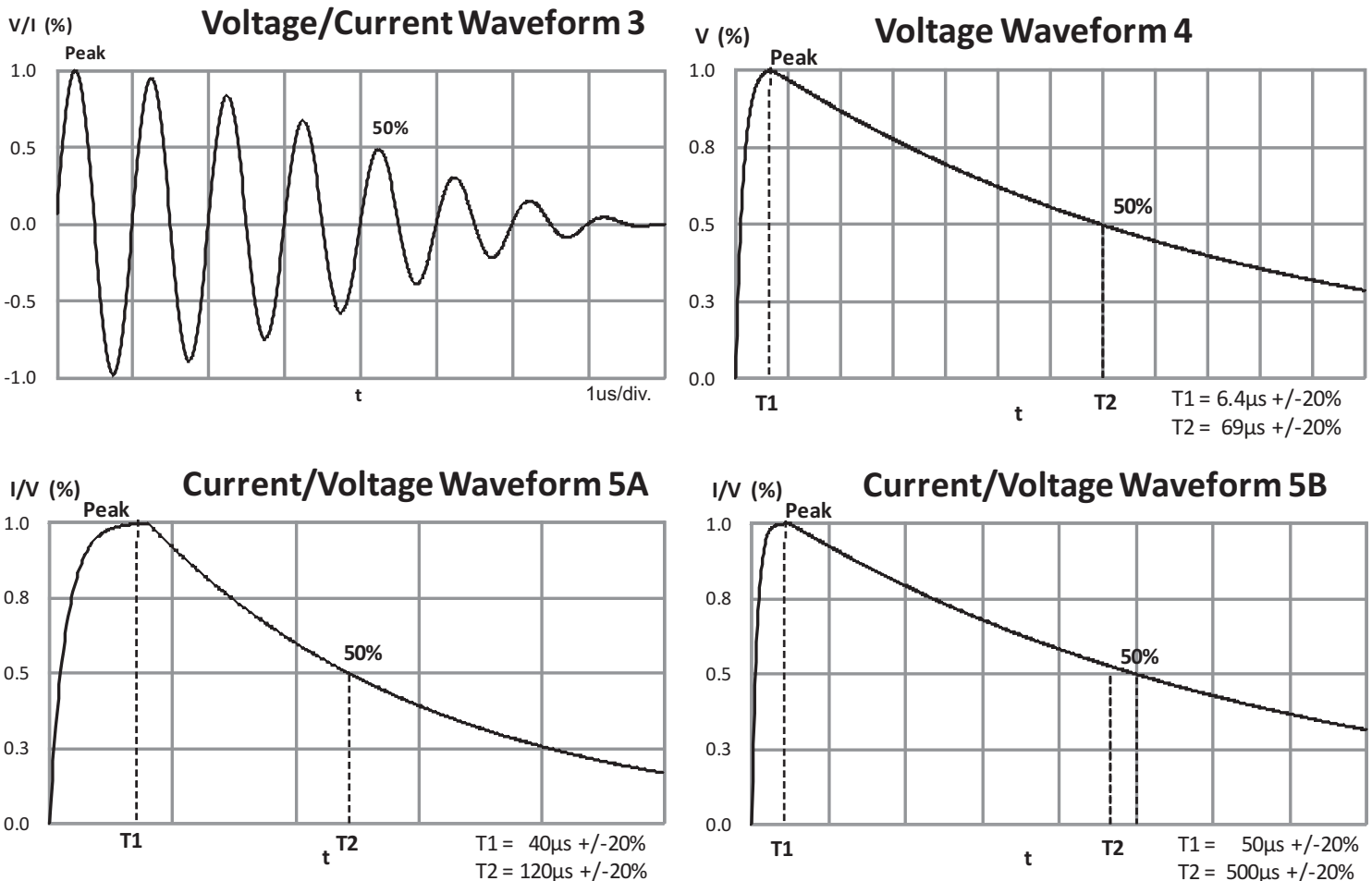

Figure 3. Lightning Waveforms

APPLICATION EXAMPLES

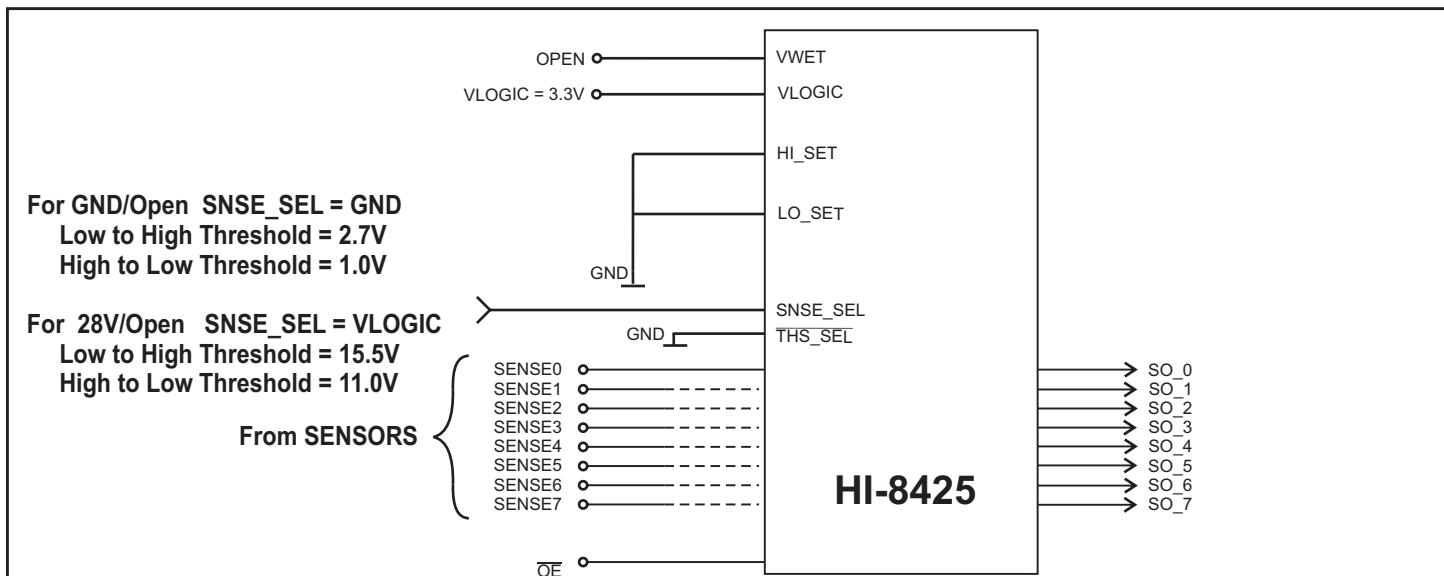

Figure 4 Input Sensing with Internal Thresholds

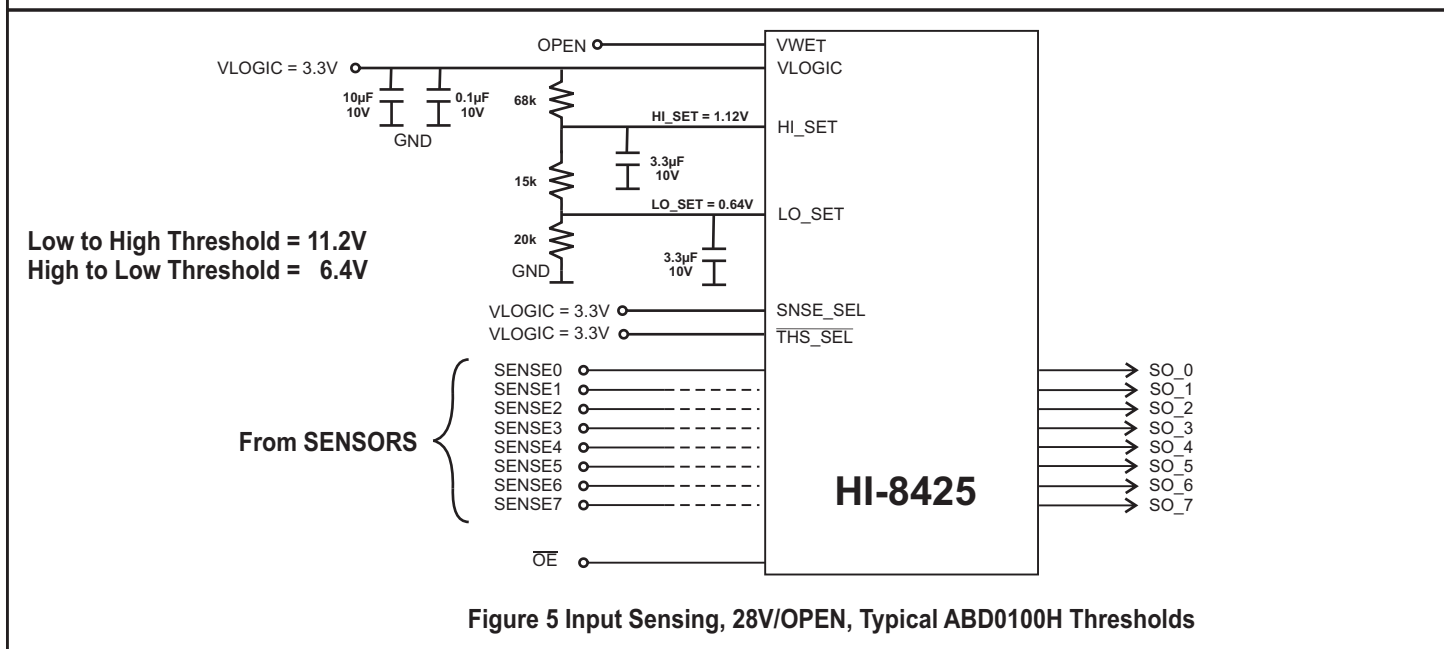
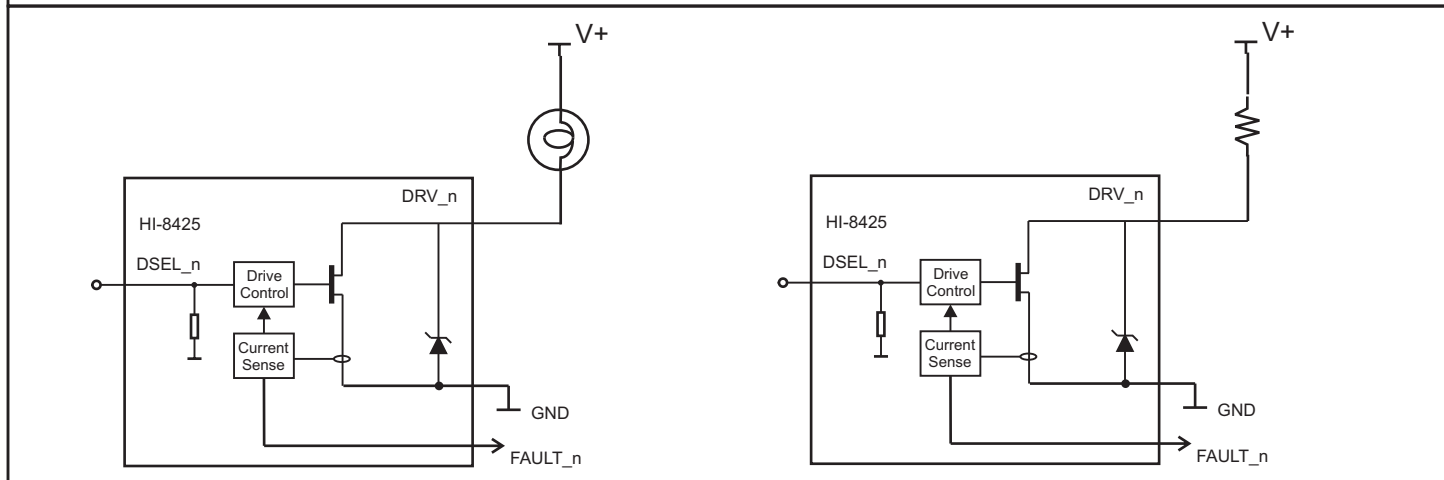
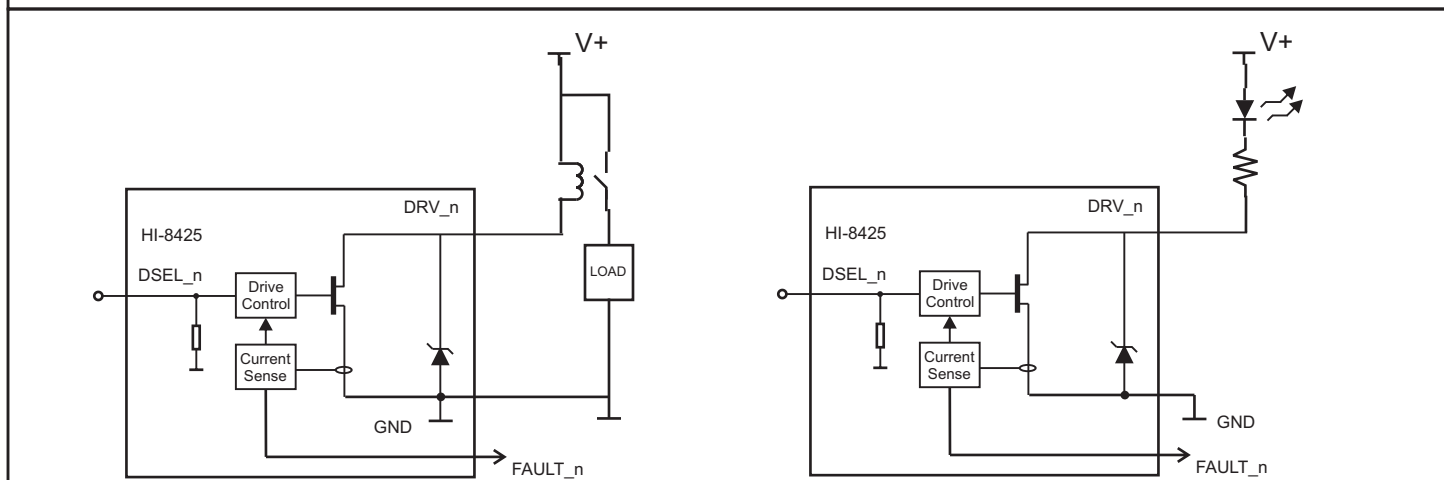
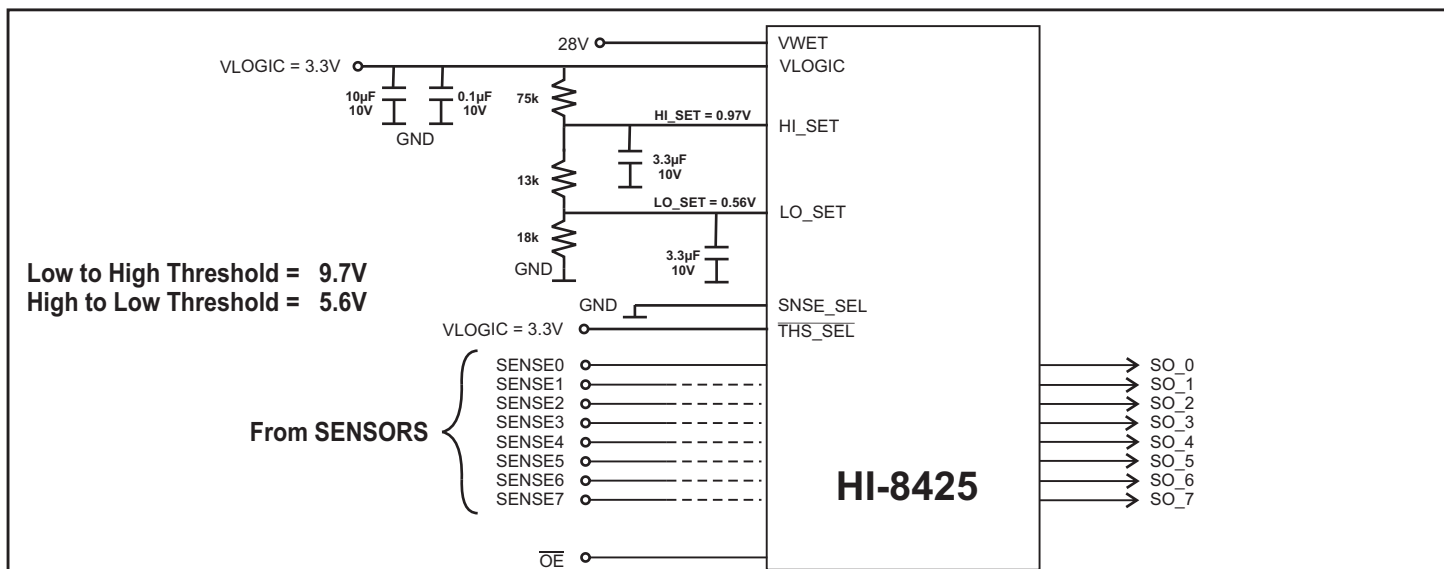

Figure 5 Input Sensing, 28V/OPEN, Typical ABD0100H Thresholds

APPLICATION EXAMPLES





# APPLICATION EXAMPLES

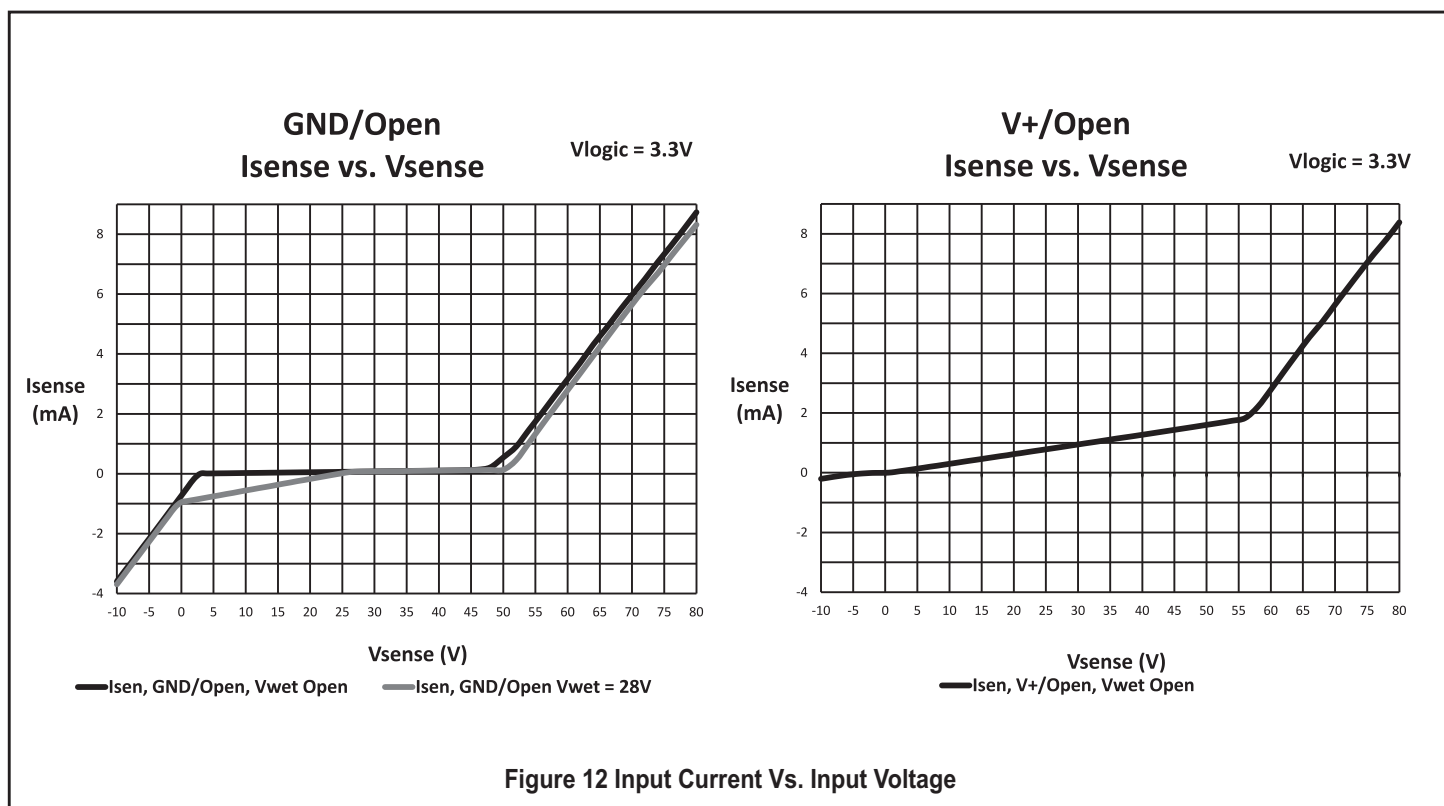
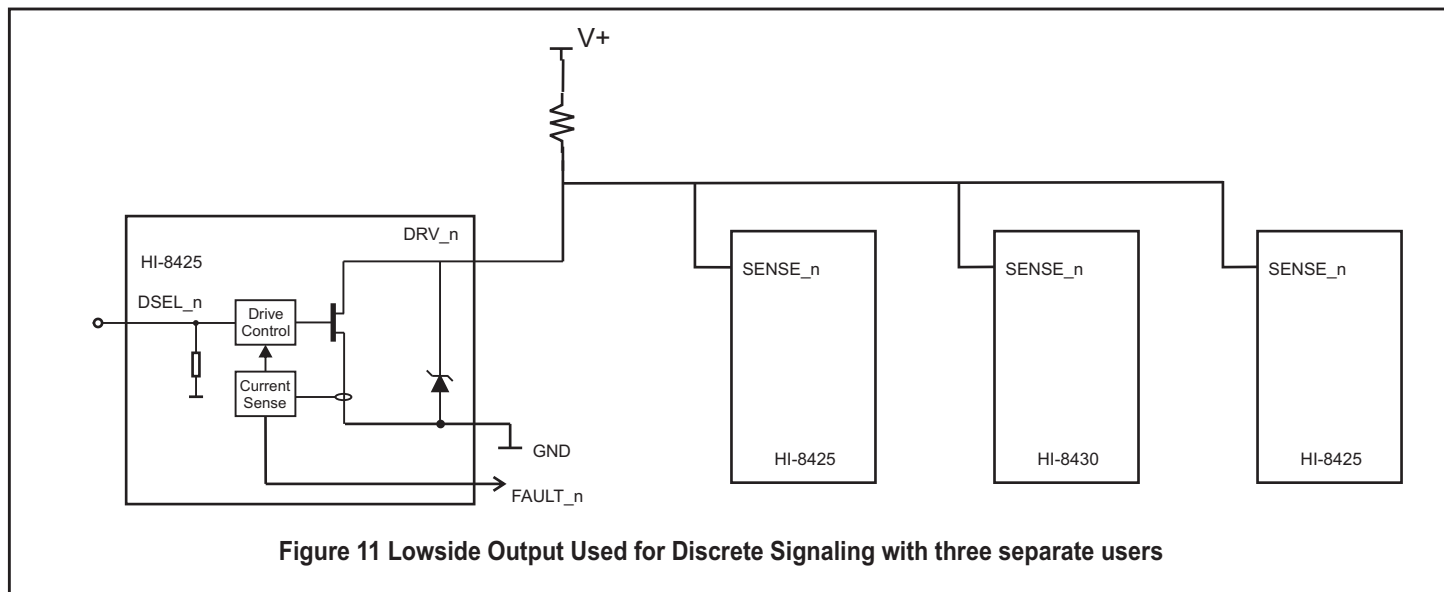

## ABSOLUTE MAXIMUM RATINGS

Voltages referenced to Ground	
Supply Voltage (VLOGIC)	-0.3V to +7V
DRV_n	55V
VWET	-0.3V to +55V
DC Driver Current per pin	300mA
Logic Input Voltage Range	-0.3V to VLOGIC+0.3V
Discrete Input Voltage Range	-80V to +80V
Continuous Power Dissipation (TA=+70°C)	
QFN (derate 21.3mW/°C above +70°C)	1.7W
QFP (derate 10.0mW/°C above +70°C)	1.5W
Solder Temperature (reflow)	260°C
Junction Temperature	175°C
Storage Temperature	-65°C to +150°C

## RECOMMENDED OPERATING CONDITIONS

Supply Voltage	
VLOGIC	3.0V to 5.5V
VWET	7.0V to 36V
Operating Temperature Range	
Industrial Screening	-40°C to +85°C
Hi-Temp Screening	-55°C to +125°C

NOTE: Stresses above absolute maximum ratings or outside recommended operating conditions may cause permanent damage to the device. These are stress ratings only. Operation at the limits is not recommended.

## D.C. ELECTRICAL CHARACTERISTICS

VLOGIC = 3.3V or 5V, GND = 0V, TA = Operating Temperature Range (unless otherwise specified).

PARAMETER	SYMBOL	CONDITION	MIN	TYP	MAX	UNITS
<b>DISCRETE INPUTS</b>						
<b>SENSE V+/OPEN</b>		SEN_SEL = High, VWET floating				
Resistance to Ground	RIN			30		kΩ
<b>Case 1: THS_SEL = GND</b>						
Open State Input Voltage	VOS	Input voltage to give High output			11.0	V
V+ State Input Voltage	VV+	Input voltage to give Low output	15.5			V
Input Current at 28V	IIN28	VIN = 28V		0.95		mA
Hysteresis	VHY		1.5			V
<b>Case 2: THS_SEL = Open or VLOGIC</b>						
HI_SET Threshold Range	VTHI	HI Threshold is set to HI_SET X 10	0.4		2.2	V
LO_SET Threshold Range	VTLO	LO Threshold is set to LO_SET X 10	0.3		2.1	V
Min Threshold Window	VTHW	HI_SET > LO_SET	0.1			V
Sense Threshold Accuracy		Voltage referred to the sense input, see table 2	VTLO - 0.5		VTHI + 0.5	V

## D.C. ELECTRICAL CHARACTERISTICS (cont)

VLOGIC = 3.3V or 5V, GND = 0V, TA = Operating Temperature Range (unless otherwise specified).

PARAMETER	SYMBOL	CONDITION	MIN	TYP	MAX	UNITS
<b>DISCRETE INPUTS</b>						
<b>SENSE GND/OPEN</b>						
Resistance in series with diode to VLOGIC	R <sub>IN</sub>			3.3		kΩ
Resistance in series with diode to VWET	R <sub>W</sub>			23.8		kΩ
<b>Case 1: <math>\overline{\text{T HS\_SEL}} = \text{GND}</math></b>						
Internal Threshold Mode						
Ground State Input Voltage	V <sub>GS</sub>	Input voltage to give High output			1.0	V
Open State Input Voltage	V <sub>OS</sub>	Input voltage to give Low output VLOGIC = 5.5V VLOGIC = 3.15V	3.75 2.5			V
Input Current at 0V	I <sub>IN28</sub>	V <sub>IN</sub> = 0V, VLOGIC = 3.0V V <sub>IN</sub> = 0V, VLOGIC = 5.5V		-0.65 -1.65		mA mA
Hysteresis	V <sub>HY</sub>		0.15			V
<b>Case 2: <math>\overline{\text{T HS\_SEL}} = \text{Open or VLOGIC}</math></b>						
HI_SET/LO_SET pins set Thresholds						
HI_SET Threshold Range	V <sub>THI</sub>	HI Threshold is set to HI_SET X 10	0.4		2.2	V
LO_SET Threshold Range	V <sub>TLO</sub>	LO Threshold is set to LO_SET X 10	0.3		2.1	V
Min Threshold Window	V <sub>THW</sub>	HI_SET > LO_SET	0.1			V
Sense Threshold Accuracy		Voltage referred to the sense input, see table 2	V <sub>TLO</sub> - 0.5		V <sub>THI</sub> + 0.5	V

<b>LOGIC INPUTS</b>						
Input Voltage	V <sub>IH</sub>	Input Voltage HI	80%			VLOGIC
	V <sub>IL</sub>	Input Voltage LO			20%	VLOGIC
Input Current, $\overline{\text{OE}}$ , DSEL <sub>n</sub>	I <sub>SINK</sub>	V <sub>IN</sub> = VLOGIC, 30kΩ pull down		125		μA
	I <sub>SOURCE</sub>	V <sub>IN</sub> = GND			0.1	μA
Input Current, $\overline{\text{T HS\_SEL}}$	I <sub>SINK</sub>	V <sub>IN</sub> = VLOGIC	0.1			μA
	I <sub>SOURCE</sub>	V <sub>IN</sub> = GND, 30kΩ pull up		125		μA
Input Current, SNSE_SEL	I <sub>SINK</sub>	V <sub>IN</sub> = VLOGIC	0.1			μA
	I <sub>SOURCE</sub>	V <sub>IN</sub> = GND,	0.1			μA

## D.C. ELECTRICAL CHARACTERISTICS (cont)

VLOGIC = 3.3V, GND = 0V, TA = Operating Temperature Range (unless otherwise specified).

LOGIC OUTPUTS						
Output Voltage	V <sub>OH</sub>	I <sub>OH</sub> = -100μA	90%			VLOGIC
	V <sub>OL</sub>	I <sub>OL</sub> = 100μA			10%	VLOGIC
Output Current	I <sub>OL</sub>	V <sub>OUT</sub> = 0.4V	1.6			mA
	I <sub>OH</sub>	V <sub>OUT</sub> = VLOGIC - 0.4V			-1.0	mA
Tri-State Leakage Current	I <sub>TSL</sub>	VLOGIC > V <sub>out</sub> > GND	-1.0		1.0	μA
Output Capacitance	C <sub>O</sub>			15		pF

PARAMETER	SYMBOL	CONDITION	MIN	TYP	MAX	UNITS
<b>ANALOG INPUTS</b>						
HI_SET/LO_SET Leakage Current	I <sub>L</sub>	Max leakage for VLOGIC > V <sub>input</sub> > GND	-0.1		1.0	μA
<b>LOW SIDE DRIVERS</b>						
On Resistance	R <sub>ON</sub>	I <sub>SOURCE</sub> = 200mA See Figure 16		4.5	8	Ω
Off Resistance	R <sub>OFF</sub>	DRV_n = 28V, n = 0,1,2 or 3	5.0			MΩ
Over Current Threshold	V <sub>DCMAX</sub>	Maximum V <sub>DS</sub> before current limiting. See Figure 17	1.5			V
Over Current Delay	T <sub>OC</sub>	Period that Driver sinks max current. See Figure 17	5	11		μs

SUPPLY CURRENT						
VLOGIC Current	I <sub>DD1</sub>	All Sense Pins Open			10	mA
VWET Current	I <sub>VWET</sub>	All Sense Inputs = 0V, VWET = 28V			12	mA

## AC ELECTRICAL CHARACTERISTICS

VLOGIC = 3.3V or 5V, GND = 0V, TA = Operating Temperature Range (unless otherwise specified).

PARAMETER	SYMBOL	CONDITION	MIN	TYP	MAX	UNITS
<b>SENSE V+/OPEN</b>						
Delay, Output going High	tH1	See Figure 13, $\overline{\text{THS\_SEL}} = \text{GND}$ , 25°C		1.0		μs
Delay, Output going Low	tL1	See Figure 13, $\overline{\text{THS\_SEL}} = \text{GND}$ , 25°C		1.0		μs
<b>SENSE GND/OPEN</b>						
Delay, Output going High	tH2	See Figure 14, $\overline{\text{THS\_SEL}} = \text{GND}$ , 25°C		1.0		μs
Delay, Output going Low	tL2	See Figure 14, $\overline{\text{THS\_SEL}} = \text{GND}$ , 25°C		1.0		μs
<b>TRI-STATE DELAY</b>						
Tri-state Delay, On	tTSON	See Figure 15, $\overline{\text{THS\_SEL}} = \text{GND}$ , 25°C			40	ns
Tri-state Delay, Off	tTSOFF	See Figure 15, $\overline{\text{THS\_SEL}} = \text{GND}$ , 25°C			40	ns
<b>LOW SIDE DRIVERS</b>						
Turn On Delay, DSEL_N	tSON	See Figure 16, VLOGIC = 3.3V, 25°C	400			ns
Turn Off Delay, DSEL_N	tSOFF	See Figure 16, VLOGIC = 3.3V, 25°C			900	ns
Fault Output Delay, On	tFON	See Figure 17, VLOGIC = 3.3V, 25°C			15	μs
Fault Output Delay, Off	tFOFF	See Figure 17, VLOGIC = 3.3V, 25°C			15	μs

# TEST CIRCUIT AND TIMING DIAGRAMS

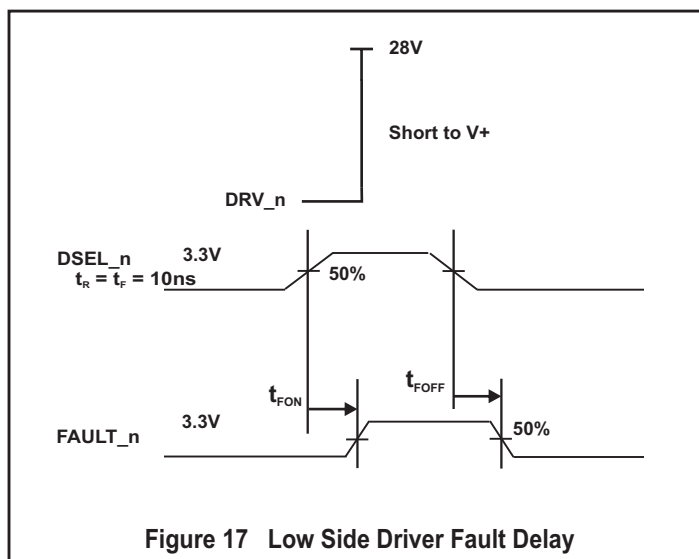
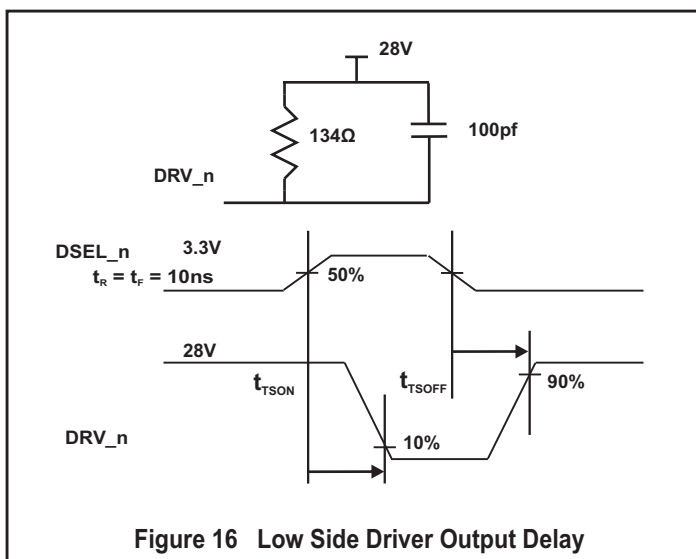
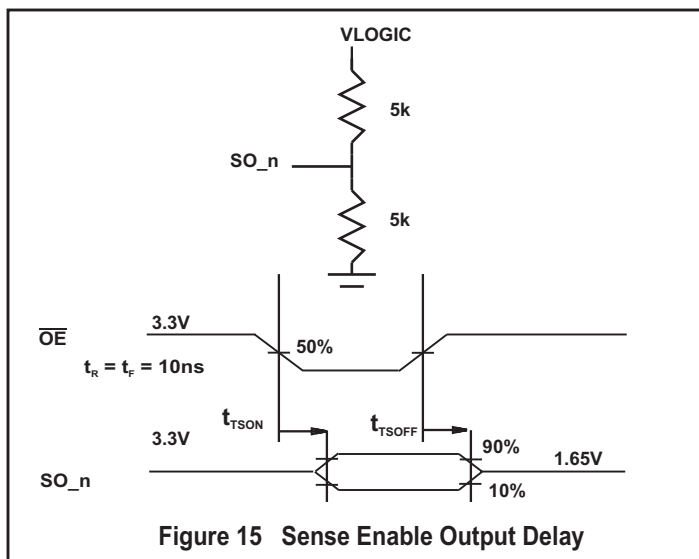
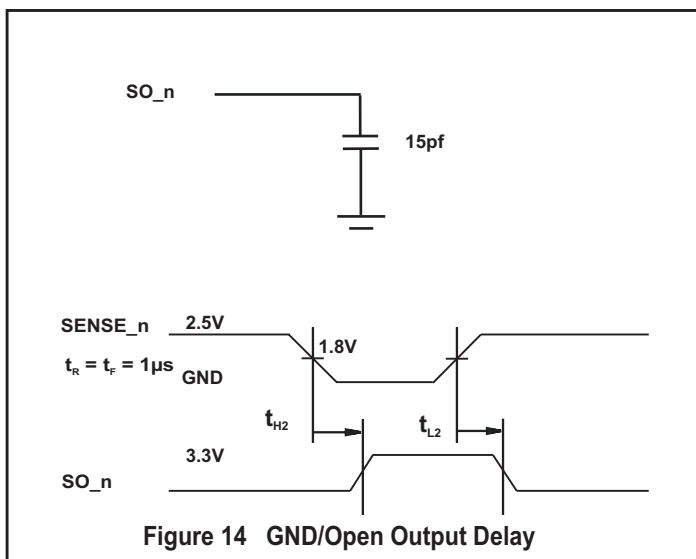
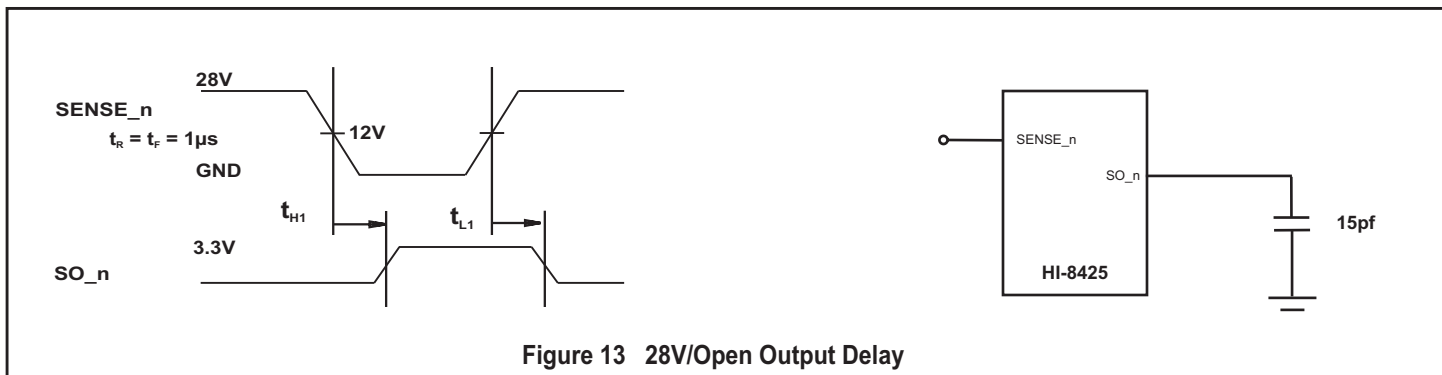

**ORDERING INFORMATION**

**HI - 842xPQ x x**

PART NUMBER	LEAD FINISH
Blank	Tin / Lead (Sn /Pb) Solder
F	100% Matte Tin (Pb-free, RoHS compliant)

PART NUMBER	TEMPERATURE RANGE	FLOW	BURN IN
I	-40°C TO +85°C	I	NO
T	-55°C TO +125°C	T	NO
M	-55°C TO +125°C	M	YES

PART NUMBER	PACKAGE DESCRIPTION
8425PQ	44 PIN PLASTIC QUAD FLAT PACK (44PMQS)
8426PQ	32 PIN PLASTIC QUAD FLAT PACK (32PQS)

**HI - 842xPC x x**

PART NUMBER	LEAD FINISH
Blank	NiPdAu
F	NiPdAu (Pb-free RoHS compliant)

PART NUMBER	TEMPERATURE RANGE	FLOW	BURN IN
I	-40°C TO +85°C	I	NO
T	-55°C TO +125°C	T	NO
M	-55°C TO +125°C	M	YES

PART NUMBER	PACKAGE DESCRIPTION
8425PC	40 PIN PLASTIC CHIP SCALE (40PCS)
8426PC	32 PIN PLASTIC CHIP SCALE (32PCS)

ADDITIONAL PACKAGE CONFIGURATIONS

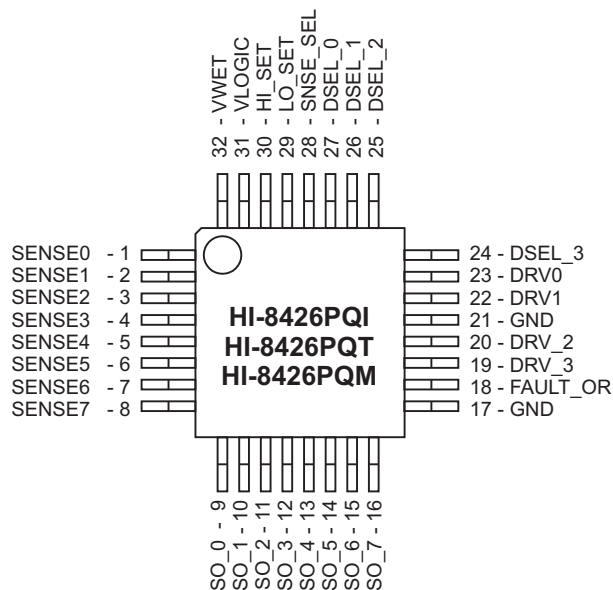

32 - Pin Plastic Quad Flat Pack (PTQFP)  
7mm x 7mm body

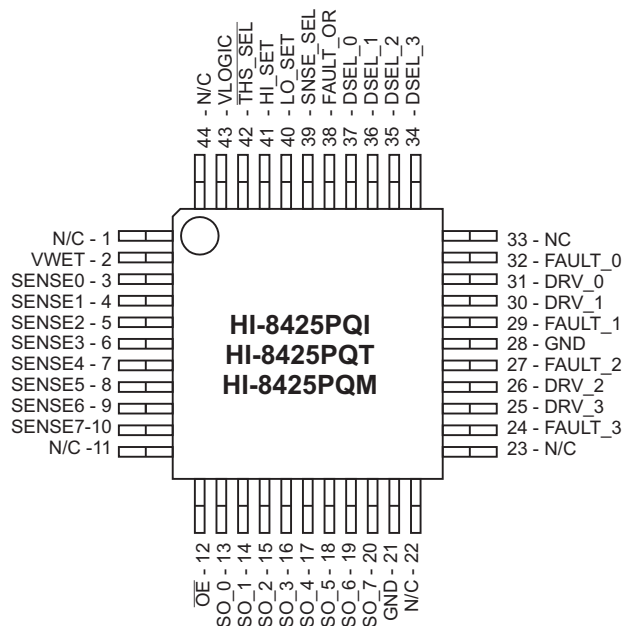

44 - Pin Plastic Quad Flat Pack (PQFP)  
10mm x 10mm body



## REVISION HISTORY

P/N	Rev	Date	Description of Change
DS8425	NEW	12/03/12	Initial Release
	A	03/11/13	Correct reference to pull-up resistor on inputs from 3.5k to 3.3k. Update VWET estimation formulas. Clarify VWET value for GND/Open and V+/Open sense options in DC Characteristics table. Update Figure 12 Input Current vs. Input Voltage charts. Delete Sensing Application Table. Add more detailed Table 2 instead. Updated Electrical Characteristics
	B	03/25/13	Corrected typos in internal threshold limits for V+/Open with VWET open. Was 11.5V. Should be 11.0V.
	C	08/20/13	Updated Discrete Input Voltage Range from +/-60V to +/-80V.
	D	10/23/13	Add "M-Grade" to PQFP and QFN package options. Reference AN-305 for lightning protection.
	E	02/25/15	Clarify ABD0100H compliance of sense inputs. Update QFN-32, QFP-44 and QFP-32 package drawings.
	F	11/03/15	Clarify voltage range for VWET. Clarify Sense Threshold Accuracy parameter.
	G	03/27/17	Correct Sense Threshold Accuracy from +/-25% to +/-0.5V. Correct other minor typos.
	H	02/07/18	Add MIL-STD-704 compliance statement for sense inputs.
	J	03/11/19	Change VWET max. from 20mA to 12mA. Add clarification to Lightning Protection description.
	K	09/20/2019	Add parameter for OFF Resistance to DC Characteristics. Update QFN package lead finish to NiPdAu. Correct 32PCS package dimension.
	L	03/26/2020	Correct typo in Over-Current Shutdown section. "sourcing" should read "sinking".
	M	08/07/2020	Change test condition for GND/Open Internal Threshold measurement from 3.0V to 3.15V. Correct typos (VDD should be VLOGIC).
	N	10/20/2022	Update 40-pin QFN package drawing (40PCS). Size of heat pad increased, package thickness reduced.

**40-PIN PLASTIC CHIP-SCALE PACKAGE (QFN)**

millimeters

Package Type: 40PCS

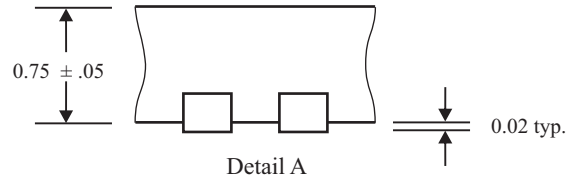
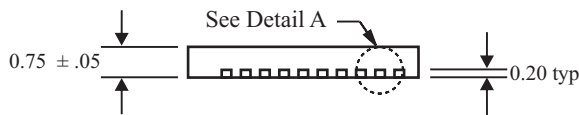
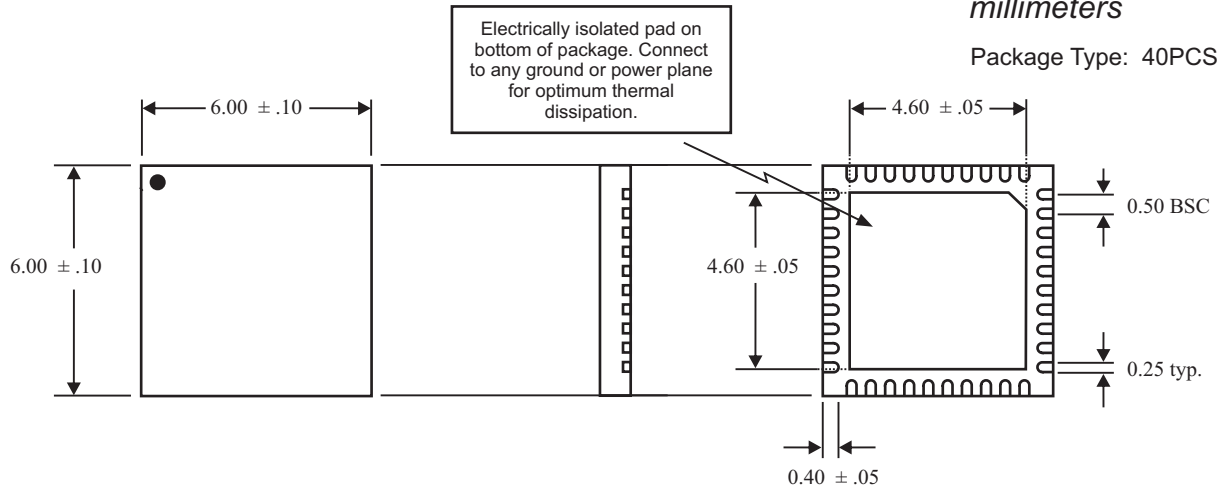

BSC = "Basic Spacing between Centers" is theoretical true position dimension and has no tolerance. (JEDEC Standard 95)

**32-PIN PLASTIC CHIP-SCALE PACKAGE (QFN)**

millimeters (inches)

Package Type: 32PCS

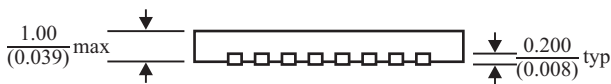
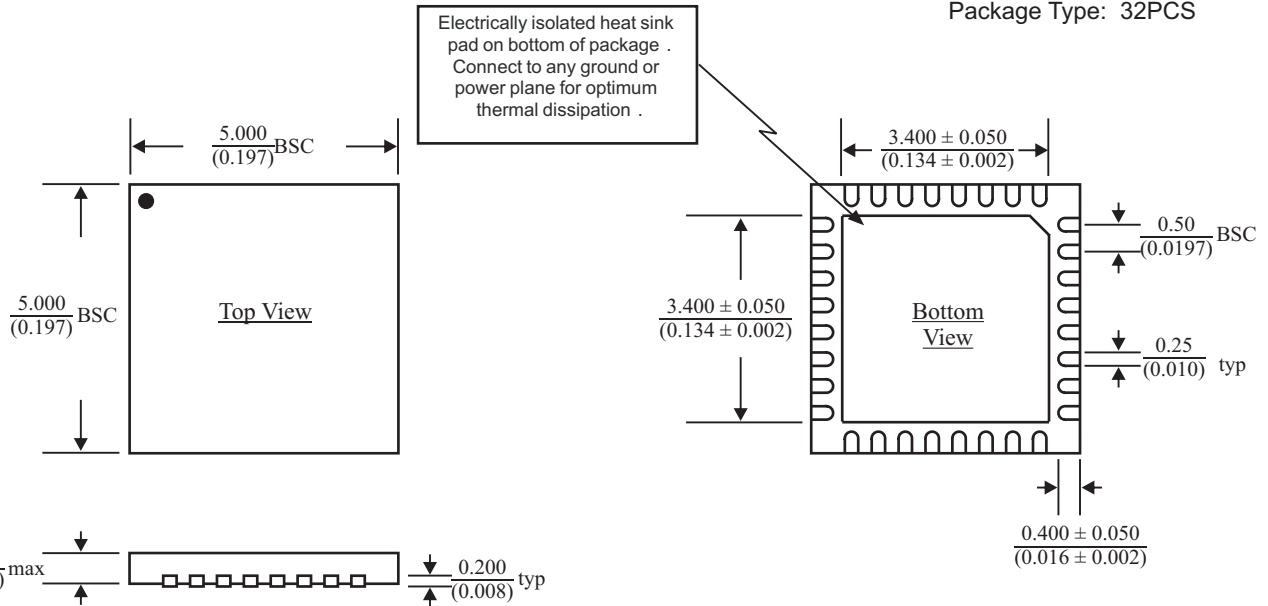

BSC = "Basic Spacing between Centers" is theoretical true position dimension and has no tolerance. (JEDEC Standard 95)

**44-PIN PLASTIC QUAD FLAT PACK (PQFP)**

*millimeters (inches)*

Package Type: 44PMQS

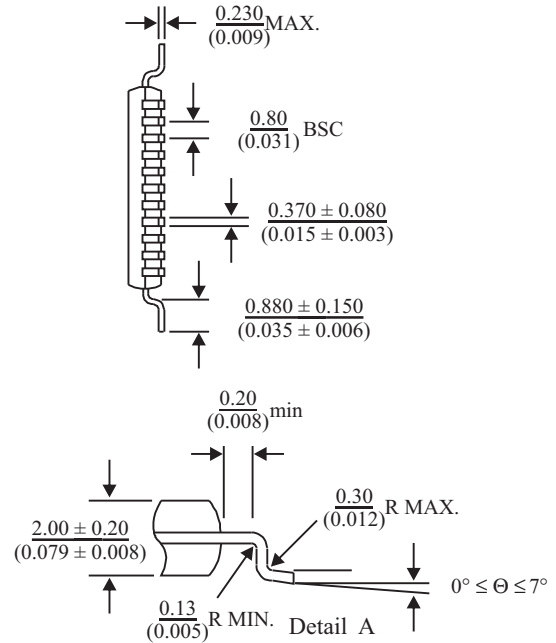
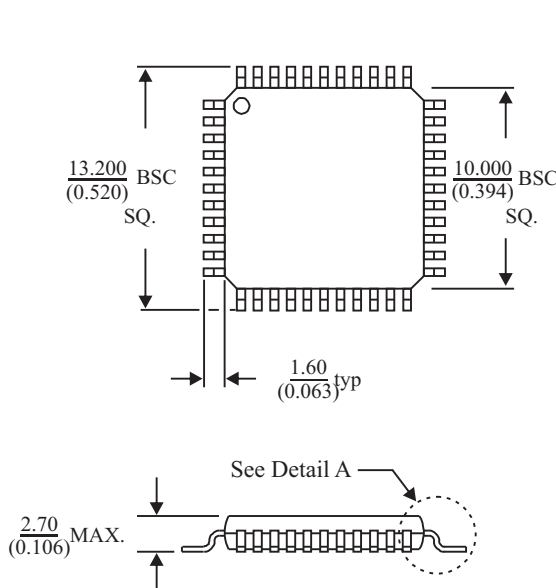

BSC = "Basic Spacing between Centers" is theoretical true position dimension and has no tolerance. (JEDEC Standard 95)

**32 PIN PLASTIC QUAD FLAT PACK (PQFP)**

*millimeters (inches)*

Package Type: 32PQS

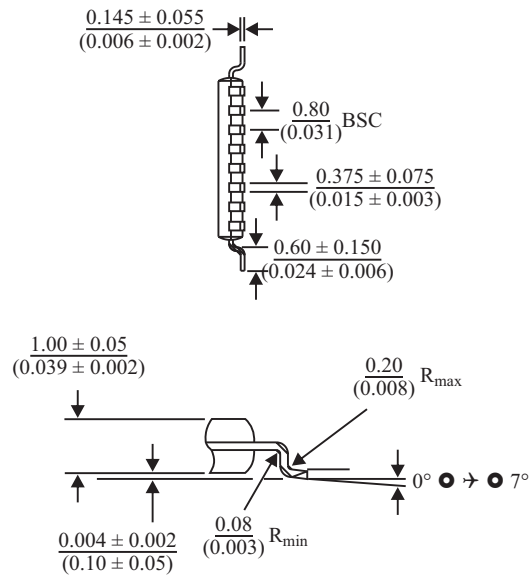
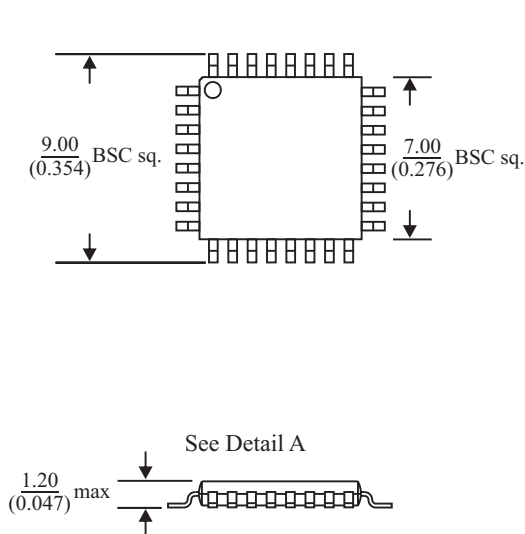

BSC = "Basic Spacing between Centers" is theoretical true position dimension and has no tolerance. (JEDEC Standard 95)