

## DC Combi Light



### applications

- Vehicles
- Aircraft
- Ships
- Shelters and Tents
- Area Lighting

### benefits

- Excellent resistance to shock and vibration
- High reliability and durability
- No requirement to replace tubes or bulbs
- Through-life cost savings over fluorescent and incandescent
- 1/3 of the power requirement for equivalent incandescent lights

### features

- Low profile LED light
- Dual mode - main and blackout lighting
- White light with red, green or blue blackout mode
- Lightweight
- 50,000 hours mean time between failure
- Available with or without dimming control
- Sealed low energy light source
- Qualified to EMC standard DEF-STAN 59-411 Land Class B\*
- Qualified to Input Voltage standard DEF-STAN 61-5 Part 5
- Sealing to IP67

Oxley has developed a range of low profile LED lights to satisfy a variety of requirements for robust, reliable and high performance lighting systems.

The DC Combi range is a series of high quality LED solutions for new build and retro-fit projects. Unique in design, the low profile and light weight units deliver white light plus an integrated blackout mode in a choice of colours.

These lights have many advantages compared to traditional incandescent and fluorescent lighting. In areas with limited space, the low profile design increases the available headroom. LED technology makes this a fit and forget solution, reducing overall costs through extended working life.

The DC Combi was originally designed for military vehicles and is also suitable for military field shelters, temporary work space lighting and naval/marine area lighting.

The Series 2 unit was developed for vehicle cab use, it has additional inputs for a door switch and ignition input. The unit also has a programming input to allow configuration by the customer. This unit has been fully qualified not only to Military DEF standards but also is E marked for road going vehicles.

The Series 3 unit features a MIL-38999 connector and meets the very stringent power input requirements of DEF-STAN 61-5 Part 6, Issue 6. It also features a separate electrically isolated input, which can be used for blackout mode selection as well as a range of external control options via PWM.

\*Unit complies with Land Class A for Conducted Emissions

**DC Combi Series 1**  
CP40357

Lightweight - 300g · Low Profile LED Light - 16mm height

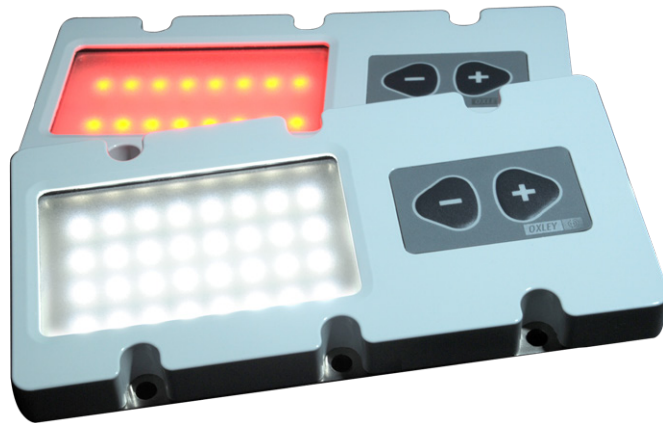

**DC Combi Series 2**  
CP42005

Lightweight - 350g · Low Profile LED Light - 21mm height



**DC Combi Series 3**  
CP40688

Lightweight - 460g · Low Profile LED Light - 27mm height\*



\*Note: This version does not offer the external dimming feature with the exception of the NVIS White which has PWM external dimming

## DC Combi Series 1

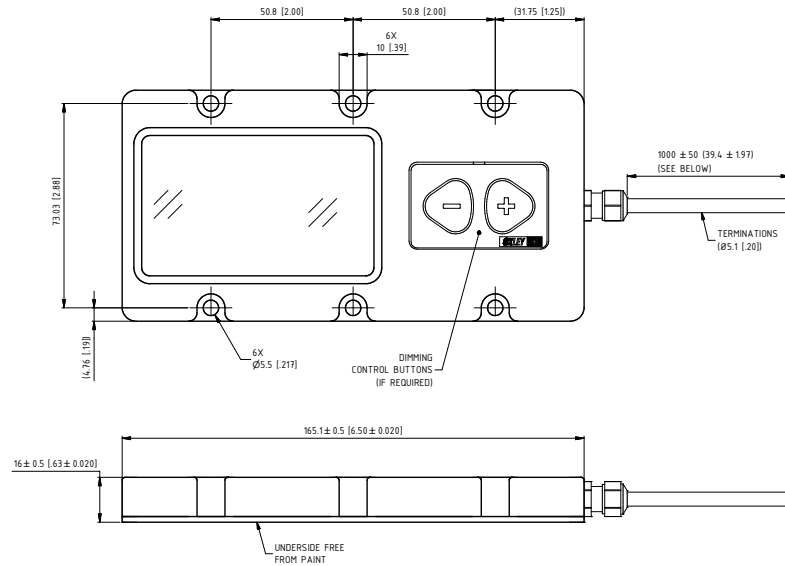

## DC Combi Series 2

### additional features

- Dimmable in both normal and blackout modes
- User selectable blackout mode using programming mode
- Door and ignition switch inputs to control light mode

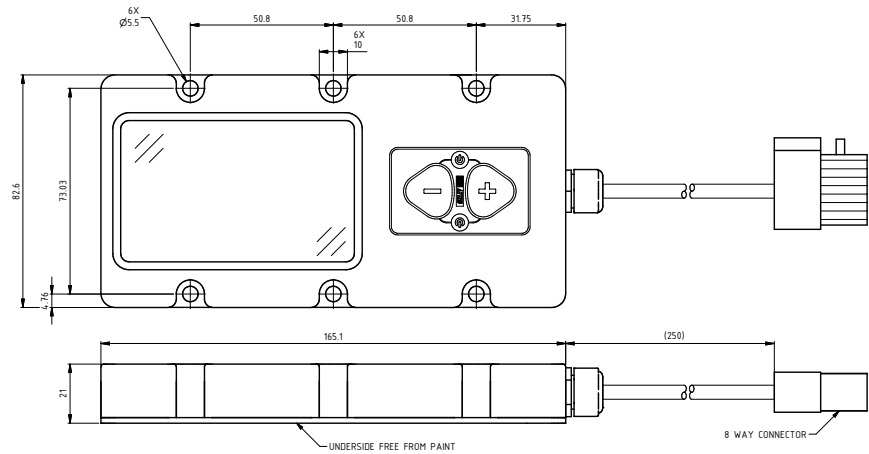

## DC Combi Series 3

### additional features

- Fitted with MIL-38999 connector
- Blackout mode where the light is off
- Warm and cool white versions available
- Dimmable in both normal and blackout modes
- Brightness storage retention when switching between modes
- Forced mode where the light provides a pre-determined level of white light
- Tactical mode where the light provides a low level of red, green, blue or NVIS White light

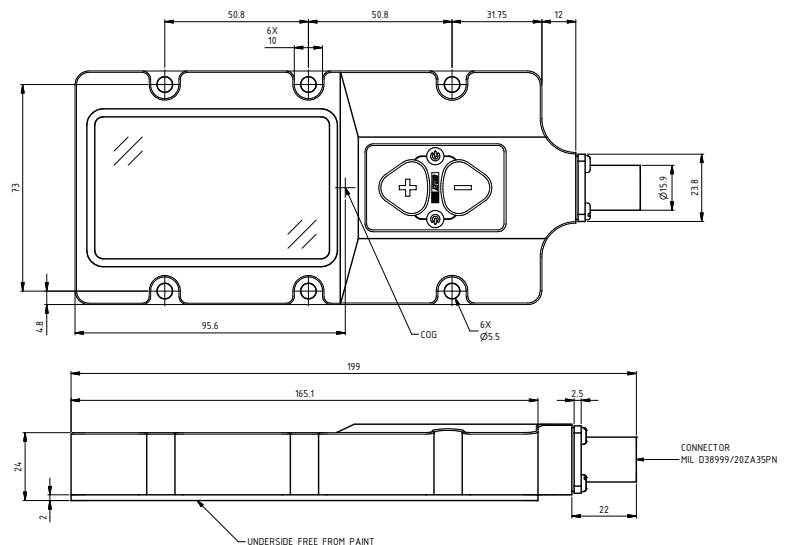

| DC COMBI TECHNOLOGY MATRIX               |                                |  |   |                           |                           |                                  |
|--|--------------------------------|--|---|---------------------------|---------------------------|----------------------------------|
|  | Series 1                       | Series 2   | Series 3                                | Series 3a                 | Series 3b                 | Series 3c                        |
| <b>Drawing Number</b>                    | CP40357                        | CP42005  | CP40688                                 | CP47640                   | CP44867                   | CP46442                          |
| DEF-STAN 59-411 Land Class A             | x                              | x  | x                                       | x                         |                           | x                                |
| DEF-STAN 59-411 Land Class B             | x                              |  | x                                       | x                         | x                         | x                                |
| DEF-STAN DEF-STAN 61-5<br>PART 6 ISSUE 5 | x                              | x  | x                                       | x                         | x                         | x                                |
| DEF-STAN DEF-STAN 61-5<br>PART 6 ISSUE 6 |                                |  | x                                       | x                         | x                         | x                                |
| MIL-STAN 1275*                           | x                              | x  | x                                       | x                         | x                         | x                                |
| MIL-STD-461E                             | x                              | x  | x                                       | x                         | x                         | x                                |
| Input Voltage                            | 11-32V                         | 11-32V   | 18-38V                                  | 18-38V                    | 18-38V                    | 18-38V                           |
| Max. Power Consumption                   | <25W                           | <16W   | <30W                                    | <30W                      | <30W                      | 30W                              |
| Primary Colour LED                       | White                          | White  | White                                   | White                     | NVIS White                | White                            |
| Second Option Colour LED                 | Red, Green<br>or Blue          | Red, Green<br>or Blue  | Red                                     | NVIS White                | n/a                       | Red, Green<br>or Blue            |
| Dimming Control Signal                   | Discrete + -<br>signal         |  | Blackout                                | Pulse Width<br>Modulation | Pulse Width<br>Modulation | Blackout                         |
| Dimming on Unit Option                   | x                              | x  | x                                       |                           | x                         | x                                |
| Dimming Externally<br>Controlled Option  | x                              | x  |   | x                         | x                         |                                  |
| Lumens Level Max                         | 1100                           | 500  | 1100                                    | 1100                      | 1100                      | 1100                             |
| Operating Temperature Range              | Minus 40°C to<br>positive 50°C | Minus 46°C to<br>positive 50°C   | Minus 46°C to positive 71°C             |                           |                           |                                  |
| Connection                               | Cable                          | Cable/connector  | MIL D38999                              | MIL D38999                | MIL D38999                | MIL D38999                       |
| Weight                                   | 350g                           | 375g   | 450g                                    | 470g MAX                  | 470g MAX                  | 450g MAX                         |
| Special Features                         |                                | Customer<br>programmable<br>Tactical colour.<br>Door input.<br>Ignition input. | Forced mode<br>- White light at 300 lux |                           |                           | Forced mode<br>default<br>1100ml |

\* Equivalency claim to DEF STAN 61-5

### Oxley Developments Company Ltd

Priority Park Ulverston Cumbria LA12 9QG United Kingdom  
t: +44 (0) 1229 483226 f: +44 (0) 1229 581851 e: sales@oxleygroup.com

### Oxley Inc

31 Business Park Drive Banford CT 06405 USA  
t: +1 (203) 488 1033 f: +1 (203) 481 6971 e: sales@oxleyinc.com

Company Approvals: BS EN ISO 9001:2015 · BS EN 9100: Rev D · BS EN ISO 14001:2015 · TSO Authorised by the FAA